



Tower Pro

USER MANUAL

HV Battery System
Tower Pro T-TP7/TP11/TP15/TP19/TP23
192 - 576V/40Ah

Contents

Statement of Law	1
Revision History	1
Safe handling of lithium batteries guide	2
1 Introduction	4
Brief Introduction	4
Product Properties	4
Product identity definition	4
2 Product specifications	6
System Performance Parameter	6
Battery Module	7
Battery controller	10
3 Installation and Configuration	14
Environmental Requirements	14
Installation location precautions	15
Installation location precautions	15
Tools	15
Safety Gear	16
Unpacking inspection	16
Equipment installation	18
4 Maintenance	23
Troubleshooting:	23
Replacement of Main Components	24
Battery Maintenance	24
5 Storage	26
6 Shipment	26

Statement of Law

Copyright of this document belongs to Dy Ness Digital Energy Technology Co., LTD. No part of this documentation may be excerpted, reproduced, translated, annotated or duplicated in any form or by any means without the prior written authorization of Dy Ness Digital Energy Technology Co., LTD. All Rights Reserved.

This product complies with the design requirements of environmental protection and personal safety. The storage, use and disposal of the products shall be carried out in accordance with the product manual, relevant contract or relevant laws and regulations.

You can check the related information on the website of Dy Ness Digital Energy Technology Co., LTD. when the product or technology is updated.

Web URL: <http://www.dyness.com/>

Please note that the product can be modified without prior notification.

Revision History

Revision No.	Revision Date	Revision Reason
1.0	2022.10.23	First Published.

Safe handling of lithium batteries guide



DANGER

Before installation or operation you must read the "Tower Pro ESS User Menu" carefully. The batteries will produce high-voltage DC power and might cause lethal voltage and electric shock.

Only qualified persons are allowed to wire the batteries.



WARNING

This product is a high-voltage DC system, and should be operated by authorized persons only.

Risk of battery system damage or personal injury.

DO NOT disconnect while the system is running!

Keep all power sources off and verify that they are de-energized.

Battery damage may result in electrolyte leakage. If the electrolyte is leaked, do not touch the leaked electrolyte or volatile gas, and contact the after-sales service team for help immediately. If leaked material was touched accidentally, please follow the steps below:

- Inhalation of leaked material: Evacuate from the contaminated area and seek medical assistance immediately.
- Eye contact: Flush with clean water for at least 15 minutes and seek medical assistance immediately.
- Skin contact: Wash the contact area thoroughly with soap and clean water and seek medical assistance immediately.
- Ingestion: Induce vomiting and seek immediate medical assistance.
- Do not move the battery system if it is connected with (to) an external expansion module.

If you need to replace or add a battery, please contact the after-sales service center.



CAUTION

Risk of battery system failure or life cycle reduction.

Before Connecting

Please check the product and packing list after unpacking. If the product is damaged or parts are missing, please contact the local dealer.

Before installation, make sure that the grid is disconnected and the battery is switched off.

Do not invert the positive and negative cables and ensure there is no short circuit to the external device.

It is prohibited to connect the battery to AC power directly.

The battery system must be properly grounded and the resistance must be less than 1Ω .

Ensure that the electrical parameters of the battery system are compatible with the respective equipment.

Keep the battery away from water and fire.

During Use

If the battery system needs to be moved or repaired, the power must be disconnected and the battery must be switched off.

It is prohibited to connect different types of batteries.

It is prohibited to connect the battery to incompatible or faulty inverters.

It is prohibited to disassemble the battery (to avoid the warranty sticker being removed or damaged).

In case of fire, only a dry powder fire extinguisher must be used, foam extinguishers are prohibited.

Please do not open, repair or disassemble batteries; this is reserved for Dy Ness staff or authorized personnel. We do not take any responsibility caused by violation of safety operation or equipment safety standards.

Maintenance

Please read the user manual carefully.

If batteries are stored for a long time, it is required to charge them every six months, and the SOC should be no less than 80%.

Batteries need to be recharged within 12 hours, after being fully discharged.

Do not expose cables outside.

All battery terminals must be disconnected for maintenance.

Please contact the supplier within 24 hours if there is something abnormal.

Warranty claims are excluded for direct or indirect damage due to items above.

1 Introduction

Brief Introduction

Tower Pro is a high-voltage battery storage system based on lithium iron phosphate batteries, and it is one of the new energy storage products developed and produced by Dyness. It can be used to support reliable power for various types of equipment and systems. Tower Pro is especially suitable for application scenes of high power, limited installation space, restricted load-bearing and long cycle life.

Product Properties

- The entire module is non-toxic, non-polluting and environmentally friendly.
- Anode material is made from LiFePO4 with safety performance and long cycle life.
- The Battery Management System (BMS) comes with protective functions including over-discharge, over-charge, over-current and high/low temperature.
- The system can automatically manage the charge and discharge state and balance the current and voltage of each cell.
- Flexible configuration, multiple battery modules can be connected in series for expanding voltage and capacity.
- Adopted self-cooling mode rapidly reduces the entire system’s noise.
- The module has less self-consumption, up to 6 months without charging; no memory effect, excellent performance of shallow charge and discharge.
- Working temperature range is from 0 to +50°C, with excellent discharge performance and cycle life.
- Small size and lightweight, standard module is easy to install and maintain.

Product identity definition

DYNESS		ENERGY STORAGE SYSTEM				
	TP7	TP11	TP15	TP19	TP23	
Nominal Energy/kWh	7.7	11.5	15.4	19.2	23.0	
Nominal Voltage/V	192	288	384	480	576	
Nominal Capacity/Ah	40	40	40	40	40	
Ambient Temp/°C	0~50	0~50	0~50	0~50	0~50	
IP Grade	55	55	55	55	55	
Protective Class	I	I	I	I	I	
<small>WWW.DYNESS-TECH.COM DAQIN NEW ENERGY TECH(TAIZHOU)CO.,LTD</small>						

Figure 1-1 Battery energy storage system nameplate



The battery voltage is higher than the safe voltage, and direct contact results in an electric shock hazard.



Be careful with your actions and be aware of the dangers.



Read the user manual before use.



Do not dispose of the scrapped batteries with household waste; they must be recycled by professional personnel or institutes.



After the useful life of the battery, it can continue to be used after being recycled by a professional recycling organization.



This battery meets European directive requirements.



This battery passed the TUV certification test.

Product Name:	HV9640
Module:	LFP Lithium Ion Battery
Capacity/Voltage:	40Ah/96V
Total Storing Energy:	3.84kWh
Charge Voltage:	105~108V
Max. Discharge Power:	3.8kW
Series Number:	┌
Manufacture Date:	
www.dy ness-tech.com DAQIN NEW ENERGY TECH(TAIZHOU) CO.,LTD	

Figure 1-2 Battery module label

2 Product specifications

System Performance Parameter

Table 2-1 Parameters of the Tower Pro system

Parameter	TP23	TP19	TP15	TP11	TP7
Module type	LFP	LFP	LFP	LFP	LFP
Total energy stored [kWh]	23.04	19.2	15.36	11.52	7.68
Usable capacity [kWh]	23.04	19.2	15.36	11.52	7.68
Recommend depth of discharge	95%	95%	95%	95%	95%
Max depth of discharge	100%	100%	100%	100%	100%
Module configuration	6 series	5 series	4 series	3 series	2 series
Voltage range [V/DC]	504 - 657	420 - 547	336 - 438	252 - 328	168 - 219
Battery system voltage (V/DC)	576	480	384	288	192
Battery system capacity (Ah)	40	40	40	40	40
Battery system charge voltage (V/DC)	657	547.5	438	328.5	219
Battery system charge current [A] (standard)	20	20	20	20	20
Battery system charge current [A] (normal)	40	40	40	40	40
Battery system charge current [A] (max)	40	40	40	40	40
Battery system discharge minimum voltage (V/DC)	504	420	336	252	168
Battery system discharge current [A] (standard)	20	20	20	20	20
Battery system discharge current [A] (normal)	40	40	40	40	40
Battery system discharge current [A] (max)	40	40	40	40	40
Battery system max charge & discharge current [A] (when used in communication with the inverter)	40	40	40	40	40
Discharge temperature range [°C]	-10 to +50	-10 to +50	-10 to +50	-10 to +50	-10 to +50
Charge temperature range [°C]	0 to +50	0 to +50	0 to +50	0 to +50	0 to +50
Max discharge power [kW]	23.04	19.2	15.36	11.52	7.68
Max charge & discharge power [kW] (when used in communication with the inverter)	13,8	11,5	9,2	6,9	4,6
Short circuit current [kA]	1.5	1.5	1.5	1.5	1.5

Parameter	TP23	TP19	TP15	TP11	TP7
Enclosure Protection (IP)	IP55	IP55	IP55	IP55	IP55
Dimensions [mm]	1672*587*	1451*587*	1230*587*	1009*587*	788*587*3
	310	310	310	310	10
Weight [kg]	241.5	206	170.5	135	99.5
Battery module name	HV9640	HV9640	HV9640	HV9640	HV9640
Number of battery modules (pcs)	6	5	4	3	2

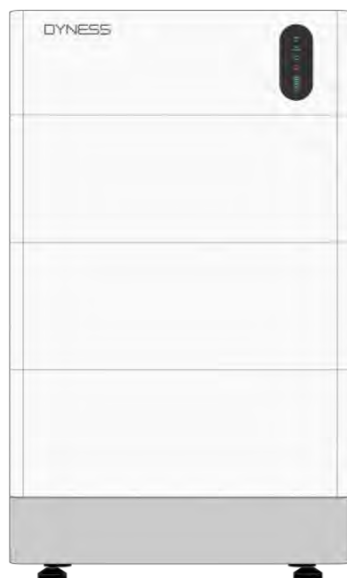

Figure 2-1 Tower Pro TP11

Battery Module



Figure 2-2 Battery module

Table 2-2 Product parameters

Module name	HV9640
Cell technology	Li-ion (LFP)
Battery module capacity (kWh)	3,84
Battery module voltage (V/DC)	96
Battery module capacity (Ah)	40
Number of battery module cells (pcs)	30

Module name	HV9640
Battery cell capacity (Wh)	128
Battery cell voltage (V/DC)	3.2
Battery cell capacity (Ah)	40
Number of battery module cells in series (pcs)	30
Battery module charge voltage (V/DC)	109.5
Battery module charge current (standard) [A]	20
Battery module charge current (normal) [A]	40
Battery module charge current (max) [A]	40
Battery module discharge minimum voltage (V/DC)	84
Battery system discharge current (standard) [A]	20
Battery module discharge current (normal) [A]	40
Battery module discharge current (max) [A]	40
Dimensions (W*D*H, mm)	587*310*241
Communication mode	CAN/RS485
Pollution degree (PD)	II
Ambient temperature (°C)	0 to +50
IP protection class	IP55
Weight (kg)	34.5

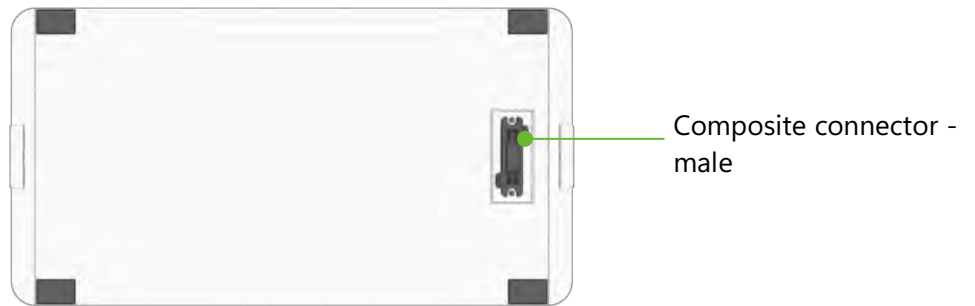

Figure 2-3 HV9640 top connector

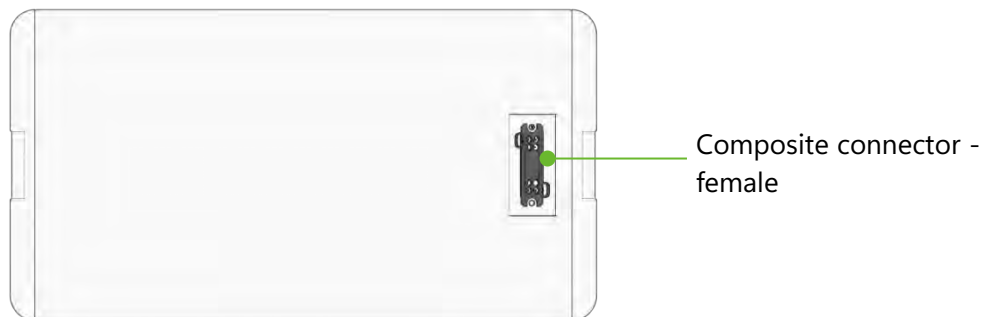

Figure 2-4 HV9640 bottom connector

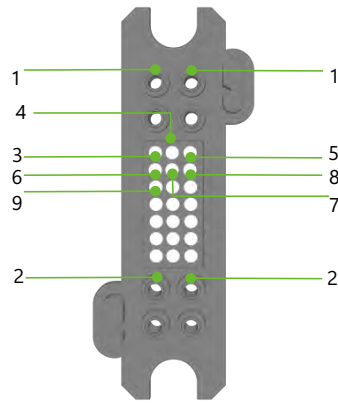

Figure 2- 5 Composite connector - male

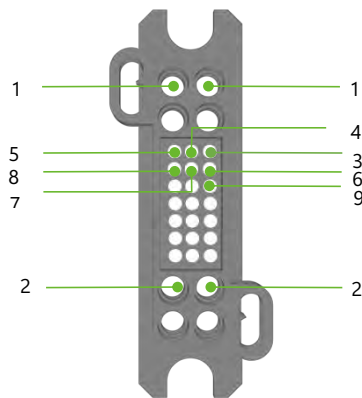

Figure 2-6 Composite connector - female

Table 2-3 Connector definition

Item	Name	Definition
1	Composite connector - male	Battery module output and communication interface
2	Composite connector - female	Battery module output and communication interface

Table 2-4 Port definition

No.	Composite connector - male	Composite connector - female
1	Negative output	Negative output
2	Module positive	Module negative
3	SWAKE	SWAKE
4	SCANSG	SCANSG
5	SCANL	SCANL
6	SCANH	SCANH
7	24V-	24V-
8	24V+	24V+

No.	Composite connector - male	Composite connector - female
9	SCANIN	SCANOUT

Battery controller

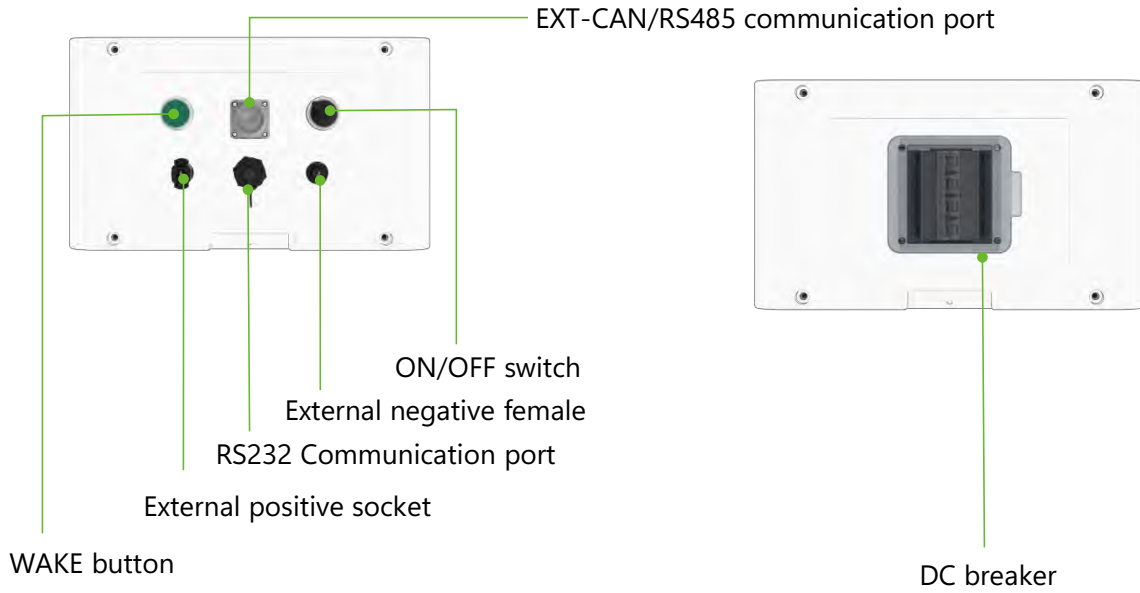

Figure 2-7 BDU right connector

Figure 2-8 BDU left connector

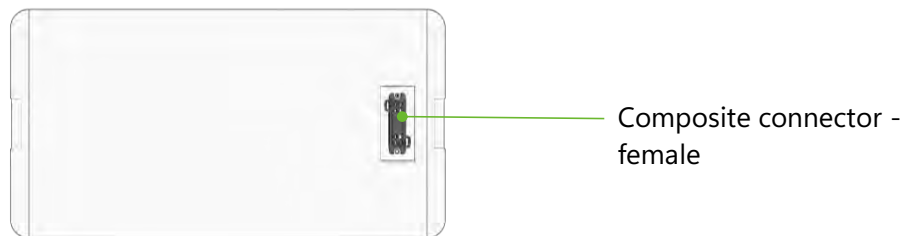

Figure 2-9 BDU bottom connector

Table 2-5 Connector definition

Item	Name	Definition
1	WAKE button	Press and hold this button for 10s to start the battery system
2	External positive socket	Connect battery system to inverter positive terminal
3	RS232 Communication port	Remote upgrade interface
4	External negative socket	Connect battery system to inverter negative terminal
5	ON/OFF switch	Switch on to start the BMS system

Item	Name	Definition
6	EXT-CAN/RS485 communication port	RJ45 communication port between battery system and inverter
7	DC breaker	The master switch of the battery system, you must switch it on before switching on the Power On and Power WAKE switches; short circuit protection.
8	Composite connector - female	Battery module output and communication interface

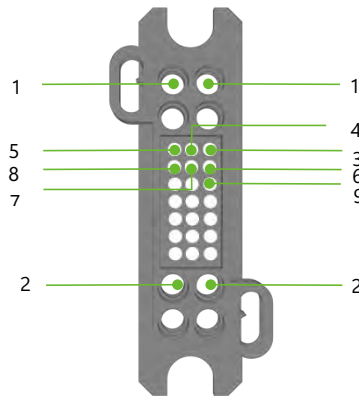

Figure 2-10 Power On switch

Table 2-6 Port definition

No.	Definition
1	Negative output
2	Positive output
3	SWAKE
4	SCANSG
5	SCANL
6	SCANH
7	24V-
8	24V+
9	SCANOUT



Figure 2-11 BDU front view

Table 2-7 LED status indicators

Battery status	SOC (%)	RUN	BAT STATE	COM	FAULT	LED1	LED2	LED3	LED4
Shutdown	OFF	OFF	OFF	OFF	OFF	OFF	OFF	OFF	OFF
Standby	75<SOC≤100	●	OFF	●	OFF	●	●	●	●
	50<SOC≤75	●	OFF	●	OFF	●	●	●	OFF
	25<SOC≤50	●	OFF	●	OFF	●	●	OFF	OFF
	0<SOC≤25	●	OFF	●	OFF	●	OFF	OFF	OFF
	SOC=0	●	OFF	●	OFF	OFF	OFF	OFF	OFF
Charging	SOC=100	●	OFF	●	OFF	●	●	●	●
	75<SOC<100	●	●	●	OFF	●	●	●	Flashing
	50<SOC≤75	●	●	●	OFF	●	●	Flashing	OFF
	25<SOC≤50	●	●	●	OFF	●	Flashing	OFF	OFF
	0≤SOC≤25	●	●	●	OFF	Flashing	OFF	OFF	OFF
Discharging	75<SOC≤100	●	Flashing	●	OFF	●	●	●	●
	50<SOC≤75	●	Flashing	●	OFF	●	●	●	OFF
	25<SOC≤50	●	Flashing	●	OFF	●	●	OFF	OFF
	10≤SOC≤25	●	Flashing	●	OFF	●	OFF	OFF	OFF
	0<SOC<10	●	OFF	●	OFF	●	OFF	OFF	OFF
	SOC=0	●	OFF	●	OFF	OFF	OFF	OFF	OFF

- If the FAULT indicator is always on, it indicates that the battery has a fault alarm.
- If the COM indicator is always on, it indicates that the communication between inverter and battery is normal.
- If the RUN indicator is always on, it indicates that the system is operating normally.
- If the BAT STATE indicator is always on, it indicates that the battery is charging.
- Flashing indicates that the battery is discharging.
- The SOC indicator is indicating the current SOC status of the battery.
- Flashing indicates that the battery is charging.

 **DANGER**

Ensure ON/OFF switch is turned on before waking up the battery. Otherwise it will affect the auto test process and cause danger.

DO NOT switch off the ON/OFF switch during normal operation, only in emergencies.

Otherwise it will cause the battery current to surge.

**CAUTION**

If the DC breaker trips because of over-current or short circuit, you must wait for 30 minutes to switch it on again, otherwise it may cause damage to the breaker.

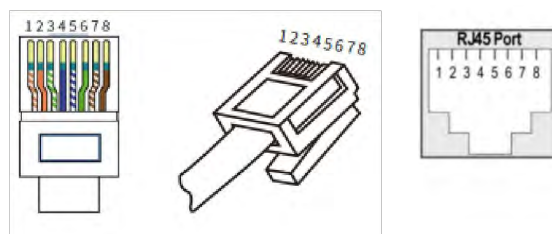

Figure 2-12 "EXT-CAN/RS485" port pins

Table 2-8 Definition of "EXT-CAN/RS485" port pins

PIN	Color	Definition
PIN1	Orange/White	485_A
PIN2	Orange	485_B
PIN3	Green/White	Reserved
PIN4	Blue	CANH
PIN5	Blue/White	CANL
PIN6	Green	CANIN
PIN7	Brown/White	CANOUT
PIN8	Brown	NC



Figure 2-13 "EXT-RS232" port pins

Table 2-9 Definition of "EXT-RS232" port pins

PIN	Color	Definition
PIN1	Orange/white	Reserve
PIN2	Orange	X+5V
PIN3	Green/white	XGND
PIN4	Blue	TX
PIN5	Blue/white	RX
PIN6	Green	XGND
PIN7	Brown/white	X+5V
PIN8	Brown	Reserve

3 Installation and Configuration

Environmental Requirements



DANGER

Cleanliness

The battery system has high voltage connectors. The environmental conditions will affect the isolation of the system.

Before installation and switch-on, dust and swarf must be removed to keep the system clean. The environment must be dust-proof to a certain extent.

Dust and humidity must be regularly checked during continuous operation of the system.

Fire Protection System

The room must be equipped with a fire protection system or fire extinguishers (Recommended: foam extinguisher). The fire protection system needs to be regularly checked to ensure its normal condition. Please refer to your local fire protection equipment for use and maintenance requirements.

Grounding System

Make sure that the grounding point for the battery system is stable and reliable before installation. If the battery system is installed in an independent equipment cabin (e.g. container), ensure that the grounding of the cabin is stable and reliable.

The resistance of the grounding system must be $\leq 100\text{m}\Omega$.



CAUTION

Temperature

Tower Pro system working temperature range: 0°C to $+50^{\circ}\text{C}$; Optimum temperature: 18°C to 30°C ; Exceeding the working temperature range will cause over-temperature/under-temperature alarms or protection of the battery system which may lead to the reduction of cycle lives.

Cooling System

It is essential to equip a cooling system to keep the battery system in a relevant temperature range. Over-temperature/under-temperature alarms or protection of the battery system may lead to the reduction of lifespan.

Heating System

It is essential to equip a heating system to keep the battery system in a relevant temperature range. If the environment is lower than 0°C , the system may be shut down for protection. It is necessary to open the heating system first. Exceeding the working

temperature range will cause the battery system over-temperature/under-temperature alarm or protection of the battery system may lead to the reduction of cycle lives.

Installation location precautions

DANGER

Please note that the battery should be installed with a minimum safe clearance from the surrounding equipment or battery. Please refer to the minimum clearance diagram below.

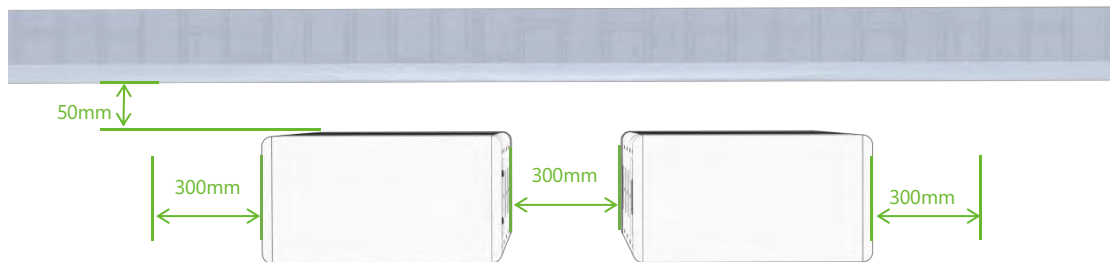

Figure 3-1 Minimum clearance

Installation location precautions

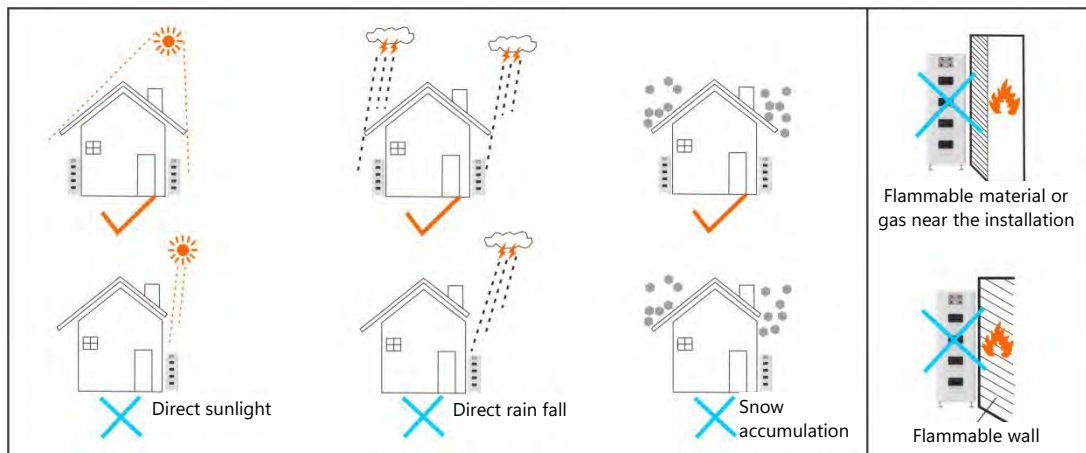

Figure 3-2 Installation location precautions

Tools

The following tools are required to install the battery pack:



Crimping tool



Pen



Phillips screwdriver



Flat screwdriver

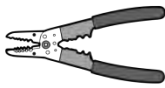

Wire stripper

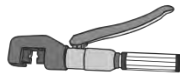

Hydraulic crimping tool



Wrench

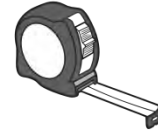

Tape measure



Hair dryer

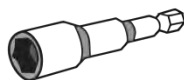

Socket wrench



Torque Wrench



Drilling machine

Figure 3-3 Installation tools

Safety Gear

We recommend wearing the following safety gear when working with batteries:



Insulated gloves



Safety goggles













Safety shoes



Figure 3-4 Safety gear

Unpacking inspection

- When the equipment arrives at the installation site, unloading should be performed according to rules and regulations, to prevent from being exposed to direct sunlight. The battery should not be installed in direct sunlight. Please refer to Section 3.3
- Before unpacking, the total number of packages shall be indicated according to the shipping list attached to each package, and all packages shall be checked for good condition.
- Handle with care and protect the surface coating of the goods.
- Upon opening the package, the installation personnel should read the technical documentation, verify the list according to configuration table and packing list and ensure that the goods are complete and intact. If the internal packing is damaged, goods should be examined and recorded in detail.

Table 3-1 Scope of delivery

Item	Specifications	Quantity	Image
Tower Pro BDU	587*310*180mm	1	
Battery module HV9640	96V/40Ah 587*310*241mm	3 pcs	
Tower Pro base	587*310*186mm	1	
Communication cable to inverter	Standard, b/L2000mm/RJ45 plug at both sides	1	
Communication connector to BDU	RJ45 waterproof connector	1	
M5 3 sets of combination screws	M5*14	8 pcs	
M6 3 sets of combination screws	M6*14	1	
Terminal	OT4-6	2	
User Manual	30 pages	1	
Power cable connector	To positive battery pole	1	
Power cable connector	To negative battery pole	1	

Item	Specifications	Quantity	Image
Power cable	Positive cable 6mm ² , red, 2m	1	
Power cable	Negative cable 6mm ² , black, 2m	1	
Wi-Fi module	For remote system update	1 pc	

Equipment installation

Installation Preparation

1. Make sure that the environment meets all technical requirements.
2. Prepare equipment and tools for installation.
3. Confirm that the DC breaker is in the OFF position.

Mechanical Installation

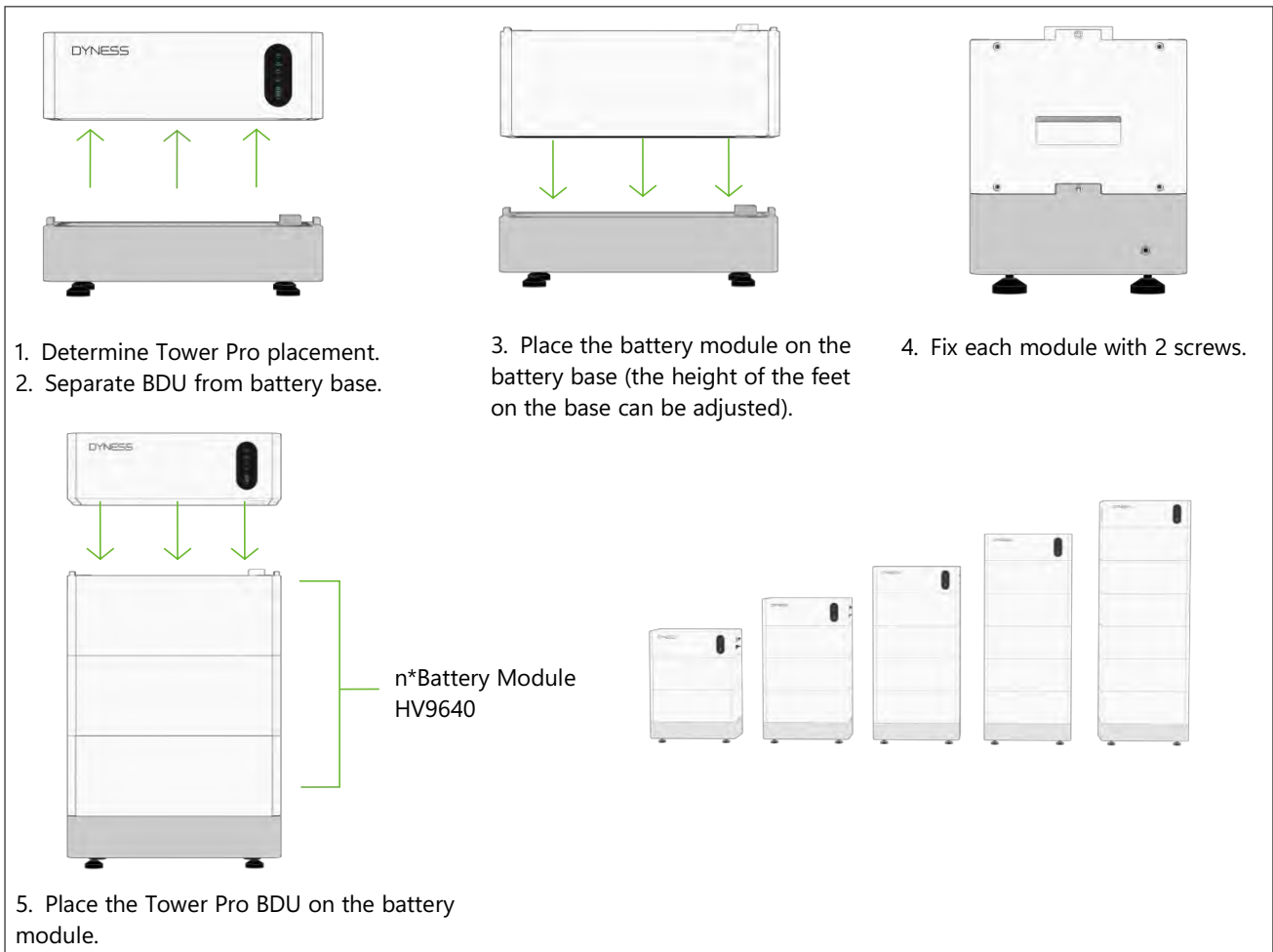

**DANGER**

The battery system is a high-voltage DC system. Ensure that installation area of Tower Pro is stable and reliable.

Please confirm that the battery system is switched off before connecting. Electric shock and damage to the inverter may be caused if the battery is connected directly without being switched off.

Otherwise, the system cannot work properly. The voltage of the battery is too high, please pay attention to self-protection during measurement.

**WARNING**

A single battery module weighs 34.5kg. It is necessary to install battery modules with helpers if no lifting equipment is available, even more so if the battery modules are installed higher up.

Double-check all the power and communication cables. Make sure that the voltage of the inverter is at the same level as the battery system.

- Switch on the inverter, and make sure that all power equipment is working normally.
- Start the battery system. See Table 3-2 Battery system self-test step 2.

Table 3-2 Battery system self-test

Step 1 Electrical installation

After the HV9640 module is stacked, it must be fixed with two screws on the left and right. The modules are fixed and connected with screws. There is a special docking point at the bottom of the battery base, as shown in the figure below:

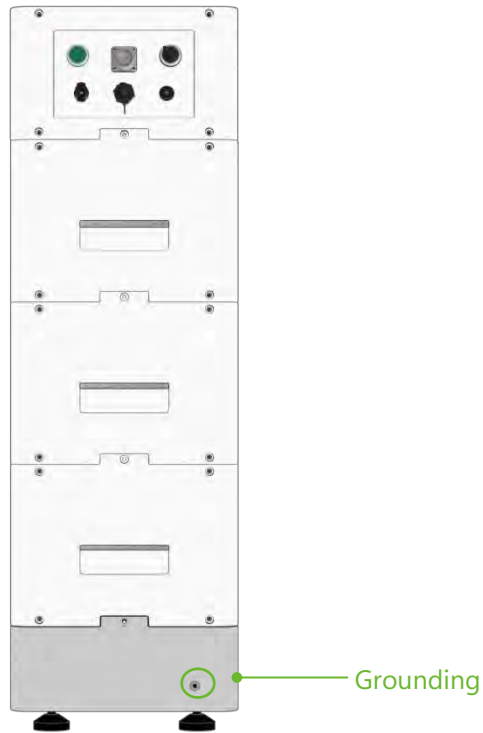

Step 2 Battery system self-test

1. Switch the DC breaker of the BDU on.



2. Switch the ON/OFF switch on



Step 2 Battery system self-test

3. Press and hold the WAKE button for approx. 10s.



Press and hold for 10s

4. Check the system output voltage.

- Use a multimeter to measure the output voltage on the positive and negative ports of the BDU.
- The output voltage should conform to the voltage range in Table "P7 Table 2-1 Parameter of the Tower Pro system".

5. Switch the ON/OFF switch off.



6. Switch the BDU DC BREAKER to OFF position.



Step 3 Connecting inverter

1. Connect the external power cable to the inverter
(If the 2m power cable is not long enough, please find another power cable of the same specification, but the length is not to exceed 3m.)

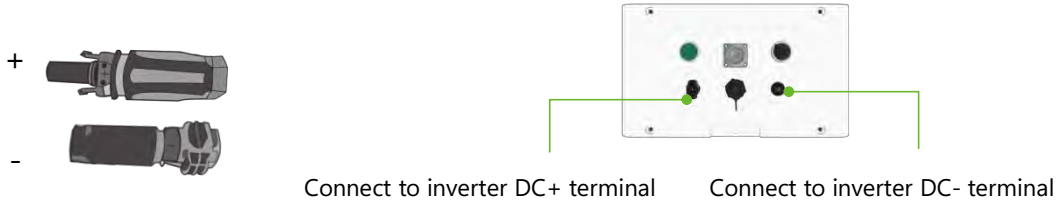

2. Connect the EXT-CAN/RS485 communication cable to the inverter RJ45 CAN/RS485 port.

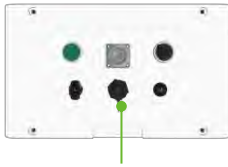

Connect to the inverter RJ45 CAN/RS485 communication port

Step 4 Connecting the Wi-Fi module

When remote upgrade program is required, connect the Wi-Fi module to the RS232 port.

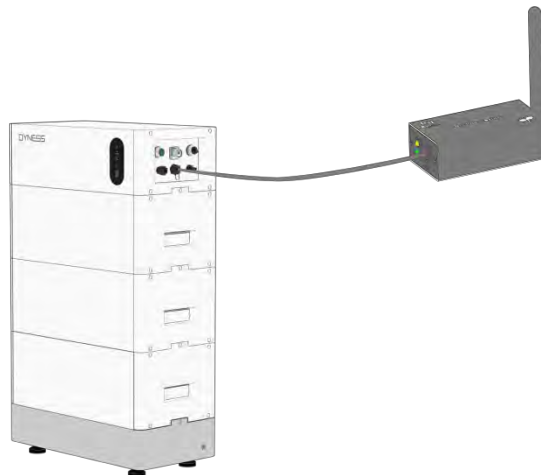

CAUTION

We recommend an external DC breaker operating both positive and negative conductors simultaneously between BDU and inverter. After waking up the BDU and ensuring that the BDU is pre-charged, it can be switched on.

4 Maintenance

Troubleshooting:



DANGER

The battery system is a high-voltage DC system. Ensure that the installation area of the Tower Pro is stable and reliable.

Please confirm that the battery system is switched off before connecting. Electric shock and damage to the inverter may be caused if the battery is connected to the inverter directly without being powered off.

Otherwise, the system cannot operate properly. The voltage of the battery is too high, please pay attention to self-protection during measurement.

No.	Problem	Possible Reason	Solution
1		The DC breaker of the BDU did not turn on	Switch the BDU DC breaker on.
2	The battery has no voltage output, and "POWER ON"/"POWER WAKE" indicator is off.	The "POWER ON" switch of the BDU is not switched on	Switch the ON/OFF switch on.
3		Battery is in sleep mode.	Press and hold the "POWER WAKE" button for about 10s
4		Battery changes into over-discharged protection.	Charge the battery to leave protection mode.
5		The BDU relay is faulty.	Replace BDU.
6	When the battery is connected to the inverter, the DC breaker trips	Short circuit between battery and inverter.	Check whether there is a short circuit between battery and inverter; Check if the inverter is faulty.
7	Communication failure between battery and inverter.	Wrong battery model is selected on the inverter	Select the correct battery model on the inverter

Replacement of Main Components

Replacing the Battery Controller (BDU)

 **WARNING**

Turn off the entire battery system. Ensure that the negative and positive terminals are de-energized.

1. Switch the ON/OFF switch off.

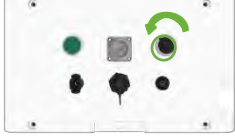

2. Switch the BDU DC BREAKER to OFF position.



- Disconnect the connecting cable.
- Remove the two screws on the BDU and remove the BDU from the system.



Figure 4-1 BDU right connector

- Exchange BDU. Then fix it with two screws.
- After replacing the new BDU, the battery self-test needs to be performed again (Refer to P20 Table 3-2 Battery system self-test)

Battery Maintenance

 **DANGER**

Battery maintenance should only be carried out by professional and authorized persons. Turn off the battery system first carrying out maintenance.

Voltage check:

[Periodical maintenance] Check the voltage of the battery system with the monitoring software. Check whether the system voltage is normal. For example: Check whether the

single cell voltage is out of range.

Voltage check:

[Periodical maintenance] Check the SOC of the battery system with the monitoring software. Check whether the SOC of the batteries is normal.

Cable check:

[Periodical maintenance] Visually inspect all cables of the battery system. Check whether the cables are broken, aging or loose.

Balancing:

[Periodical maintenance] The battery system will become unbalanced if it has not been charged fully for a long time. Solution: Perform balancing maintenance (fully charge) every 3 month. Generally this maintenance progress needs to be completed when external devices such as the monitoring software and battery and inverter have proper communication.

Output relay check:

[Periodical maintenance] Under low load (low current), check the output relay OFF and ON condition; listen if the relay clicks, which means that it switches off and on normally.

5 Storage

For long-term storage (more than 3 months), the battery cells should be stored within the temperature range of 5 to 45°C, relative humidity <65% and non-corrosive gases.

The battery module should be stored within the temperature range of 5 to 45°C, dry, clean and well ventilated environment. The battery should be charged to 50 - 55% SOC before storage.

We recommend activating the battery system (discharge and charge) every 3 months, and the longest duration of storage without charge and discharge should not exceed 6 months.



CAUTION

The lifespan of the battery will be greatly reduced if you do not follow above instructions to store the battery for a long term.

6 Shipment

The battery module is pre-charged to 50% SOC or according to customer requirements before shipment. The remaining capacity of battery cells is determined by the storage time and condition after shipment.

The battery modules meet UN38.3 certificate standard.

In particular, special rules for the carriage of goods on the road and the current dangerous goods law, specifically ADR (European Convention on the International Carriage of Dangerous Goods by Road), as amended, must be observed.



DISCOVER YOUR NATURE

Address: No. 511 Chenzhuang West Road, Sanshui Street,
Jiangyan District, Taizhou City

Email: service@dyness-tech.com

Tel: +86 400 666 0655

Web: www.dyness.com



Official Website



Digital version access